

## RH-51/52, RH-67/68 schematic diagrams

<b>Table of Contents</b>	<b>Page No</b>
Baseband connection overview	2
System connector, USB, charger	3
UEME, SIM, Zocus, Mic, Ear, IHF speaker	4
UPP, flash, MMC, camera	5
Bluetooth	6
UI, vibra	7
RF part	8
Signal overview	9
Component finder	10

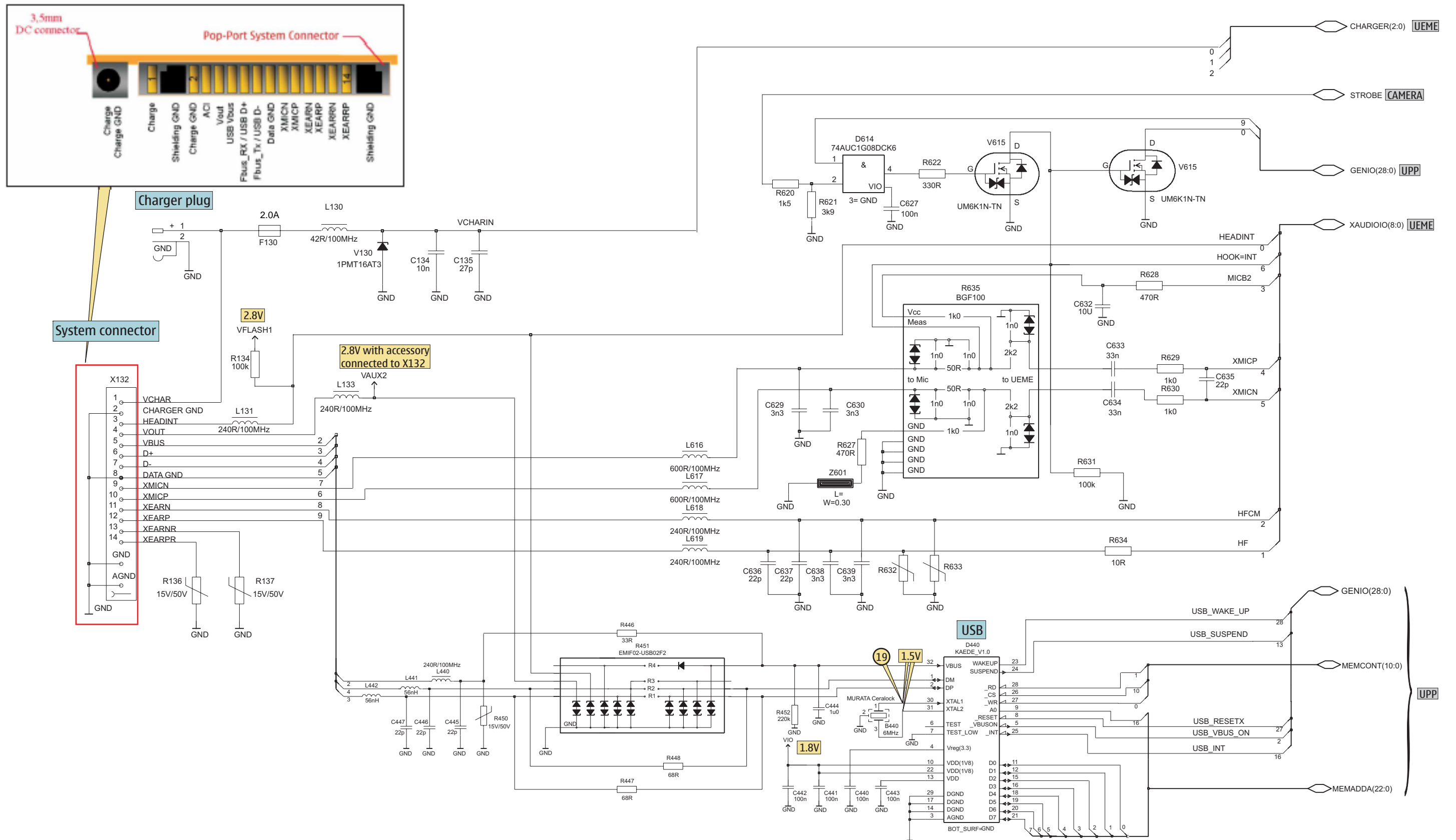

System connector, USB, charger



UEME, SIM, Zocus, Mic, Ear, IHF speaker

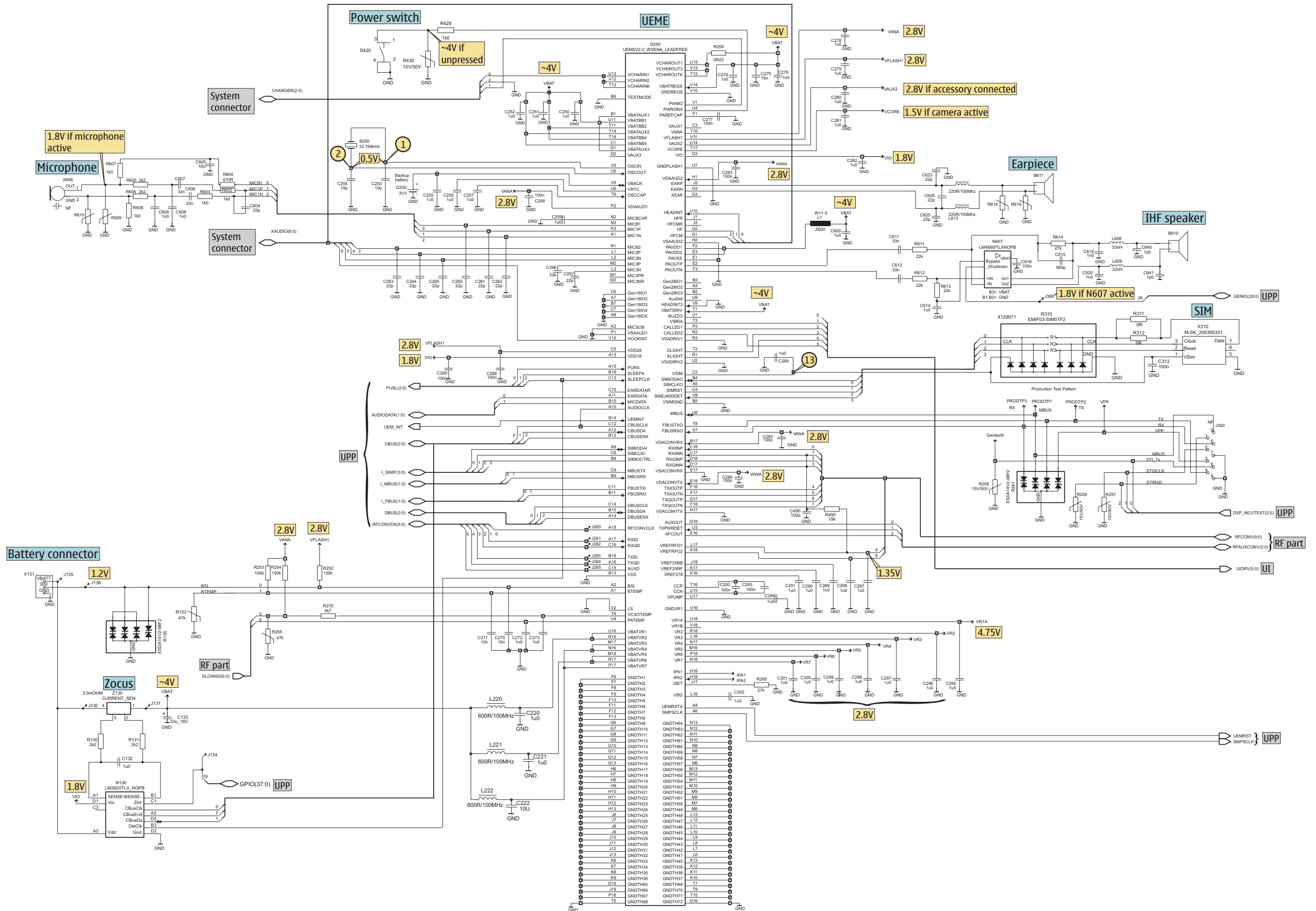



Bluetooth

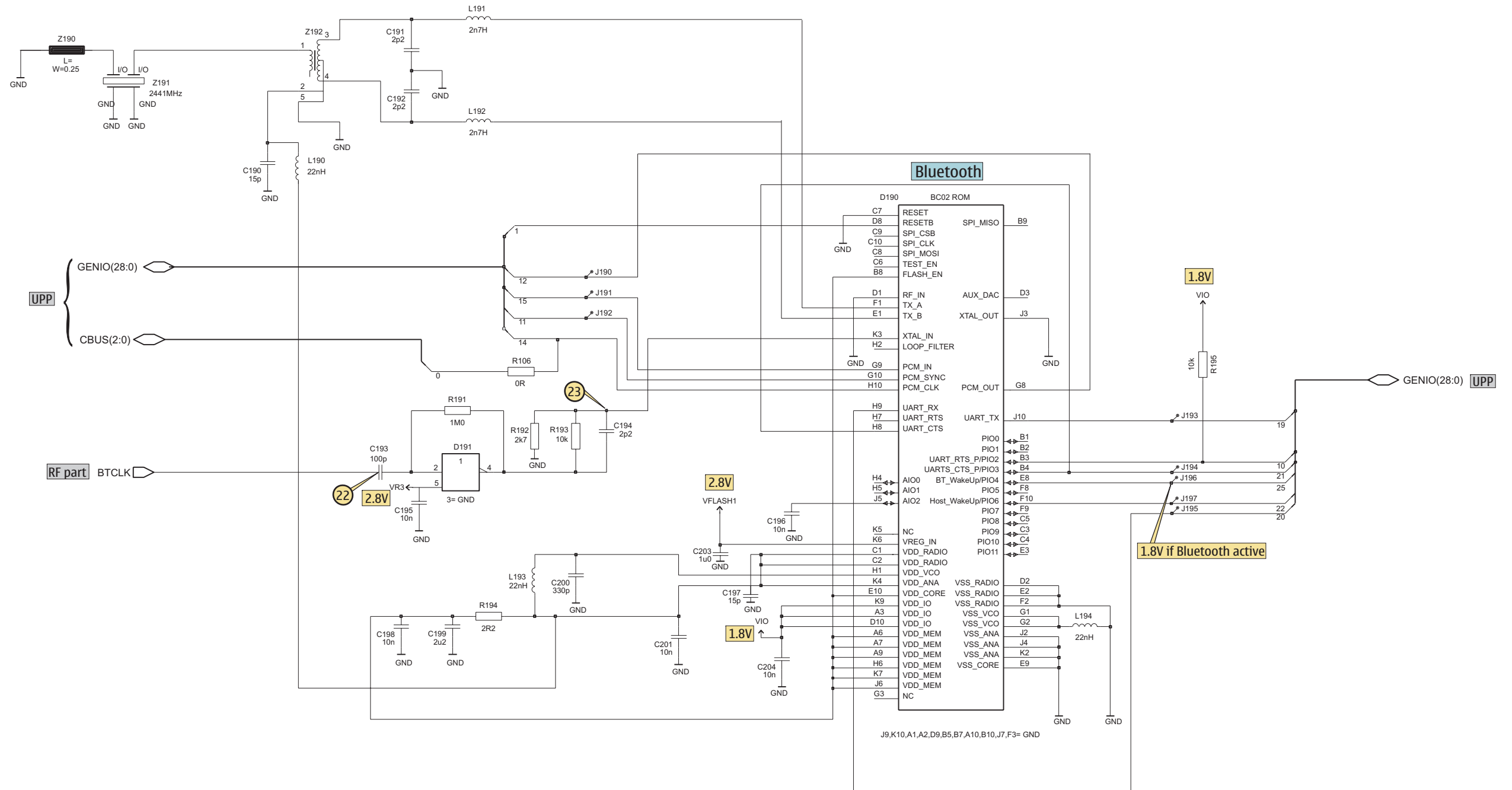

UI, vibra

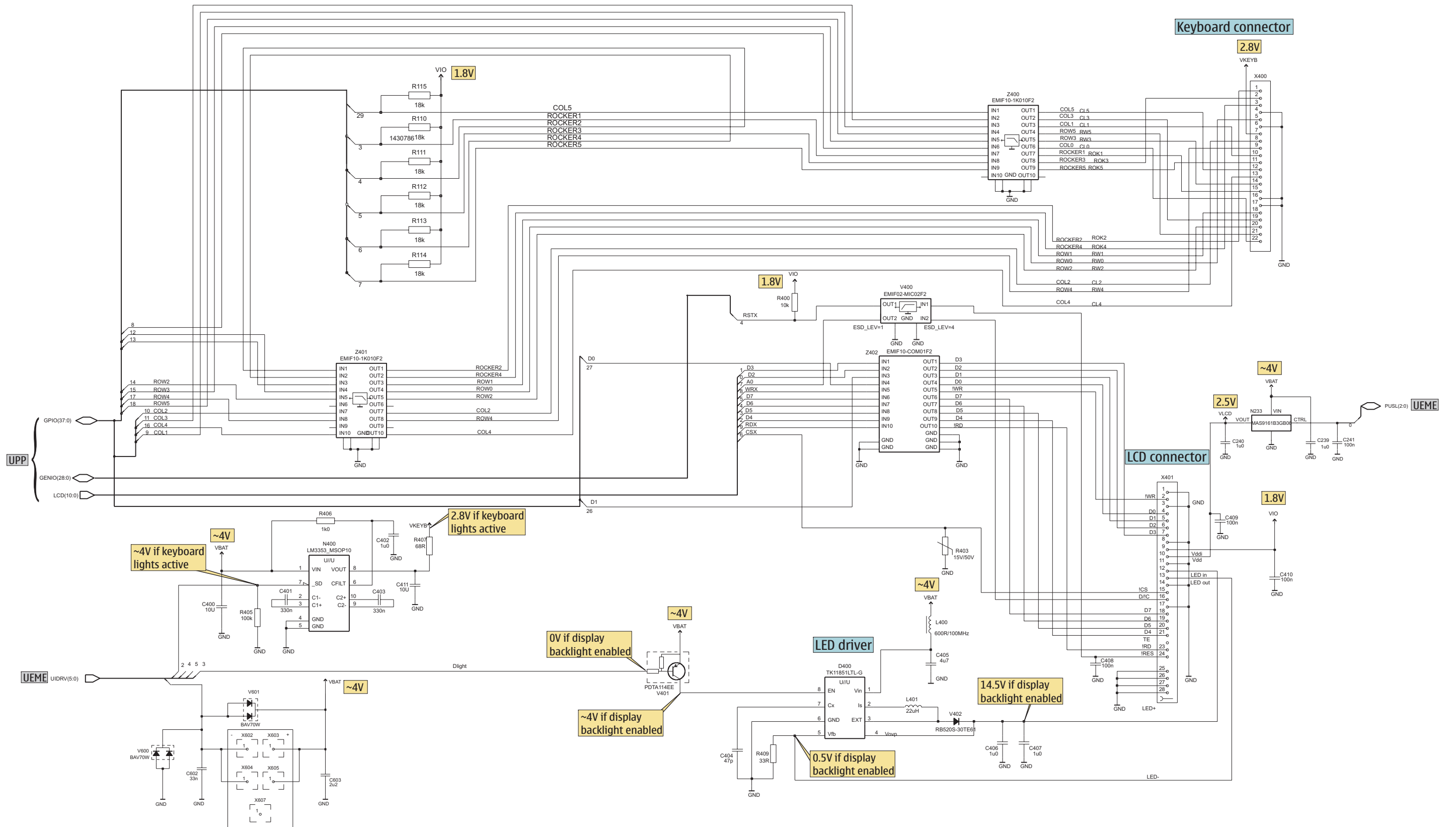

RF part

	Vc1	Vc2	Vc3
EGSM RX	-	-	-
GSM1800 RX	-	-	-
GSM1900 RX	-	2.8Vpp	-
EGSM TX	-	-	2.8Vpp
GSM1800 TX	2.8Vpp	2.8Vpp	-
GSM1900 TX	2.8Vpp	2.8Vpp	-

	RH-51 RH-67 (GSM900)	RH-52 RH-68 (GSM850)
Z700	4511443	4511445
Z803	4511455	4511449
C511	2320514	2320516

Band	Channel	RX	VCO/RX	VC/RX	TX	VCO/TX	VC/TX
EGSM 900	37	942,4MHz	3769,6MHz	~2,76V	897,4MHz	3589,6MHz	~2,03V
GSM 1800	700	1842,8MHz	3685,6MHz	~2,43V	1747,8MHz	3495,6MHz	~1,63V
GSM 1900	661	1960MHz	3920MHz	~3,34V	1880MHz	3760MHz	~2,72V

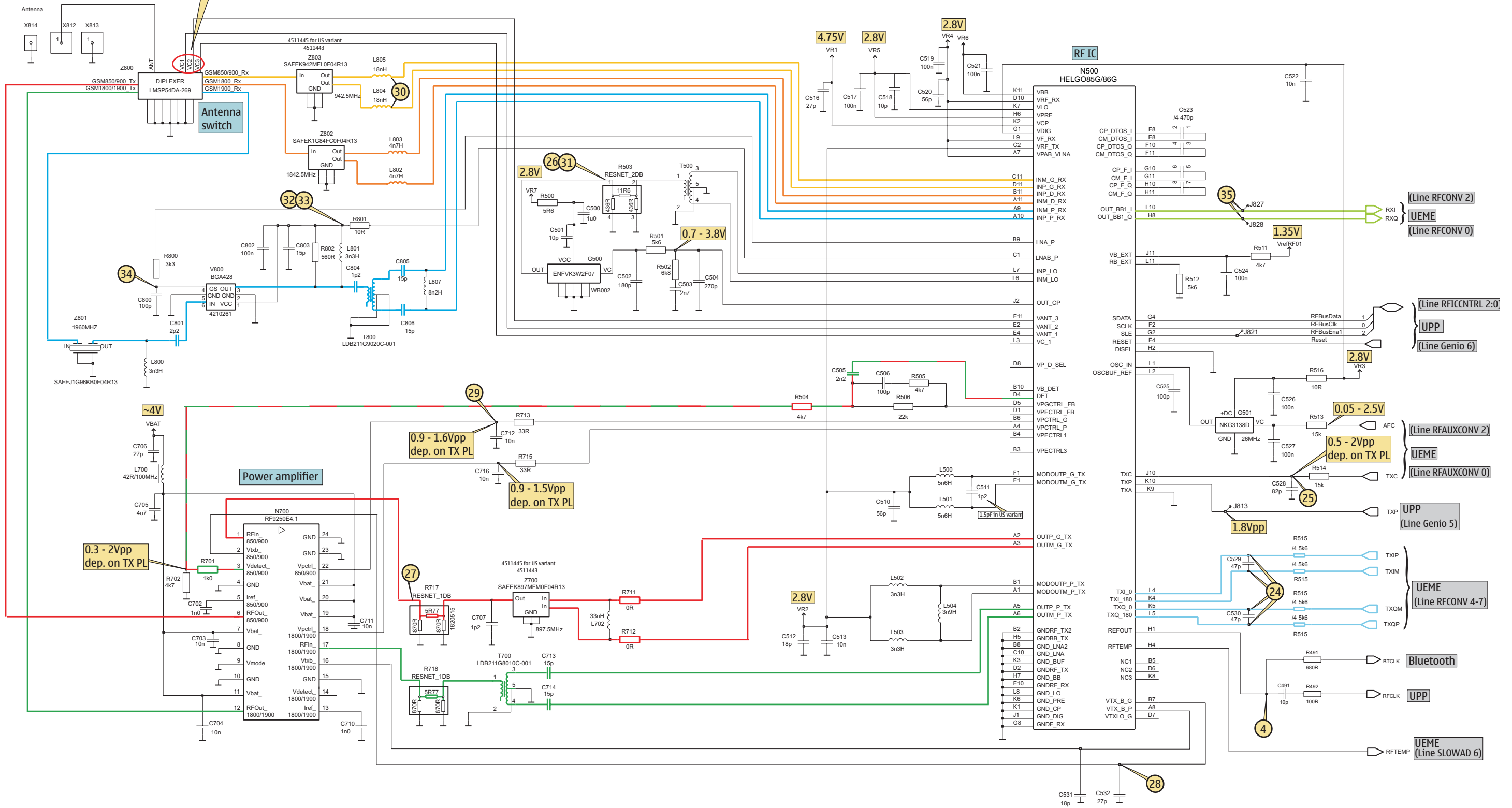



Signal overview

